

Uptodate

RSO EMEA NEWSLETTER

Security Systems | Issue April 2011

- 1 CCTV
- 2 Communications Systems
- 3 Fire
- 4 Intrusion
- 5 Access and Systems
- 6 Care Solutions

125  **Bosch**
1886-2011



BOSCH
Invented for life



Catch us!
For the latest in security solutions

125  **Bosch**
1886-2011

Bosch Video Solutions Tour

 **BOSCH**
Invented for life

CCTV

Bosch delivers AutoDome Junior HD Fixed Camera Remote commissioning provides easy installation

- ▶ HD imaging with 1080p and 720p resolutions and H.264 compression
- ▶ 10x optical/16x digital zoom enables extended monitoring range
- ▶ Remote positioning and focus make installation simple

Bosch Security Systems has expanded its AutoDome Junior HD series with a new fixed camera model. The AutoDome Junior HD Fixed Camera provides the same 1080p or 720p resolutions, 10x optical zoom and compact design as the rest of the series, making it an ideal indoor fixed camera choice for applications where both highly-detailed imaging and aesthetics are important. Banking, retail, casino, and government or commercial building applications will benefit from the camera's crisp, clear images that make it easier to identify people or small objects, such as jewelry. HD video also delivers increased situational awareness with a 16:9 aspect ratio that maximizes the field of view without compromising image details. Quad-streaming provides simultaneous streaming of high-quality video with differing frame rate and resolution settings for flexibility in system design. For example, customers can select 1080p or 720p HD video for recording with H.264 compression, while simultaneously sending JPEG images to a hand-held device.

The camera also offers built-in Intelligent Video Analysis (IVA) software to automatically process video signals and alert operators to potential security risks. The higher

pixel densities captured by the AutoDome Junior HD Fixed Camera enables optimized performance of IVA with improved detection for loitering, line crossing and other potential threats.

For easy installation, the AutoDome Junior HD Fixed Camera allows operators to commission the camera from a remote head-end unit, eliminating the need for hands-on focusing at the camera. Once the camera is configured, operators can use the built-in Web interface, the Configuration Manager from Bosch or the Video Management System from Bosch to remotely position it and fix its location without removing the

bubble or connecting a monitor directly to the camera. Power over Ethernet Plus support also enables a single cable connection to power, control and view images from the camera. In addition, conformance to the Open Network Video Interface Forum (ONVIF) standard makes it simple to integrate the camera with other IP video equipment.

The compact AutoDome Junior HD Fixed Camera is ideal for discrete surveillance. Its rugged, vandal-resistant housing helps protect the camera from damage and theft, ensuring years of reliable operation in the toughest environments.



CCTV

Bosch launches IVA-enabled camera range

Ready-to-go intelligent cameras

Pre-activated video content processing speeds-up installation and improves security

- ▶ Time - and labor-saving option – the larger the installation, the greater the saving
- ▶ IVA's digital image processing system greatly improves security and safety

Munich - Bosch introduces a new option for many of its IP network camera families – pre-activated IVA (Intelligent Video Analysis). The Dinion, FlexiDome, AutoDome, AutoDome Jr and thermal IP cameras from Bosch will now be available with IVA already enabled and ready to use. This means it is no longer necessary to buy a separate license and go online to register and activate each IVA-equipped camera. Previous options of IVA-ready (license and activation required) and non-IVA cameras are still available for most solutions.

IVA-enabled solutions are the most cost effective to buy and make installation much easier for customers, especially those with large numbers of cameras. "Imagine having a system comprising 500 cameras using IVA and going online to register and activate each one individually," says Gerard Otterspeer, Product Marketing Manager EMEA at Bosch Security Systems. "Now, with our pre-activated IVA-enabled cameras, this process can be skipped, saving many hours of work. By removing this last hurdle we are ready to bring the benefits of IVA to mainstream video security."



Cameras equipped with IVA from Bosch present a major asset to overall surveillance, supporting security personnel with a powerful and efficient event detection and alarm system. IVA is optimized for each camera family with dedicated versions installed in our HD and thermal cameras to ensure the optimal performance.

Working independently on each camera, IVA offers a wide variety of

advanced detection functions ranging from head detection to trajectory tracking. Events are immediately displayed and the data can also be stored for later review with Forensic Search from Bosch.

A complete system solution, it captures comprehensive details of recorded scenes, giving operators the power to find any event – even those not originally set up as alerts.

CCTV

Catch us!!

Bosch Video Solutions tour 2011

Experience the latest surveillance solutions first-hand

- ▶ Informative and effective demos with specialists on site to answer questions
- ▶ Focused solutions covering everything from small business to enterprise systems
- ▶ Complete HD solutions, Bosch IVA, IP 200 Series 'System-in-a-Camera', analogue solutions

Bosch began its new Video Solutions tour on March 2nd in Copenhagen visiting cities across Europe and beyond. Aimed at system integrators, consultants, engineers and distributors, the tour gives people the opportunity to catch up with the latest in security solutions and experience them first-hand. People can also find out about the benefits and features of Bosch products directly from on-site specialists. Popular demos, including model road and rail layouts, will be used to illustrate the solutions' effectiveness.

For medium-sized to enterprise applications, the tour focuses on two areas: Bosch's complete HD (High Definition) solutions portfolio and Bosch IVA (Intelligent Video Analysis). The HD portfolio encompasses everything 'from scene to screen', and delivers the highest quality HD image performance across the entire surveillance chain. Bosch IVA works independently on each camera, identifying alert conditions and signaling operators instantly, allowing them to react swiftly. IVA watches all the action all the time, greatly improving security and safety.

Those interested in surveillance for small businesses and similar applications can see a wide variety of solutions covering HD as well as both IP and analogue systems. Among the highlights is the IP 200 Series, high performance all-in-one solutions. They offer the convenience of having a



complete system – including video recording and storage – in a compact camera or dome.

Beginning in Copenhagen in Denmark and Gothenburg in Sweden the Bosch Video Solutions tour follows two routes, covering northern and southern Europe separately. The tour

will visit at least 24 cities, with each route covering about 7,000 km. There is a dedicated website www.boschsecurity.com/tour supporting the tour. It includes maps that use GPS tracking to show the current location of the tour trucks as they make their way across Europe.

CCTV

Conquers darkness and harsh daylight

Active infrared imager from Bosch captures high-quality video in all lighting conditions

- ▶ Imaging performance designed for perimeter and outdoor surveillance
- ▶ 2X-Dynamic Technology handles the most demanding lighting situations
- ▶ Variable Field Illumination provides superior performance at night

Bosch Security Systems introduces the Dinion Infrared Imager, a rugged camera designed for perimeter surveillance and other outdoor applications. With 2X-Dynamic Technology and Variable Field Illumination, the Dinion Infrared Imager consistently delivers high-quality video even in harshly lit or completely dark environments.

Available in analog and IP models, Dinion Infrared Imagers deliver up to 160 meters (525 feet) of detection level performance in low or no light. Designed to improve perimeter protection at critical sites – such as energy, transportation and defense applications – the imagers also achieve classification level surveillance up to 120 meters (390 feet) away at night, making them ideal for installation along a fence line.

The 2X-Dynamic Technology in the Dinion cameras provides 20-bit processing – twice the power of conventional cameras – and wide dynamic range sensors for unparalleled image quality in all lighting conditions. The cameras deliver excellent color reproduction and analyze unevenly-lit scenes pixel-by-pixel to produce the most detailed images, day and night. Infrared illumination compensation assures effective round-the-clock surveillance.

Variable Field Illumination provides maximum flexibility by allowing on-site

adjustment of the infrared intensity and beam shape to match the coverage area, improving image quality in the dark and simplifying installation. The infrared panels can be tilted to fit the customer's specific application, resulting in wide area coverage and reduced setup time. For increased control, customers can also change the infrared intensity or turn the illumination on or off remotely.

Patented 3D Diffuser technology provides even illumination across the entire scene to eliminate hotspot foregrounds and underexposed backgrounds. Low-noise images reduce bandwidth and storage requirements and enable night-time function of video content analysis software.

Bosch's unique Constant Light technology delivers a consistent level of imaging performance throughout the life of the product – even when operating in fluctuating temperatures. This advanced technology automatically controls and adjusts output to compensate for the degradation that naturally occurs with all LED illuminators. As a result, customers gain long-term reliability and performance.

Tri-streaming allows the Dinion IP Infrared Imager to produce high-quality H.264 images at full frame rate for live viewing and recording while concurrently sending JPEG images to a remote server or device. Built-in iSCSI support enables the camera to send video directly to a network-attached iSCSI RAID array for storage, while Power over Ethernet Plus allows a single cable to power, control and stream images from the camera.

Intelligent Video Analysis (IVA) enables the Dinion IP Infrared Imager to process video signals and automatically alert operators to potential threats. IVA allows the camera to autonomously detect suspicious behavior, such as loitering



and line crossing, and notify security personnel of a potential or impending perimeter breach, among other risks.

A quick connect system between the camera and mount makes the Dinion Infrared Imager easy to install, and an integrated on screen display with remote capability provides a single interface for controlling both infrared and camera functions. In addition, conformance with the Open Network Video Interface Forum (ONVIF) standard assures compatibility of the Dinion IP Infrared Imager with other network video products, regardless of manufacturer.

IP 67 and NEMA4X ratings ensure the imagers withstand a range of weather conditions and resist corrosion to provide years of dependable operation. The camera is tested to desert solar radiation conditions and functions in temperatures ranging from -50 to +55 degrees Celsius (-58 to +131 degrees Fahrenheit). It can endure wind speeds up to 260 kilometers (162 miles) per hour.

CCTV

Bosch adds outdoor dome cameras to HD portfolio

State-of-the-art technology for AutoDome 800 Series

- ▶ HD imaging with 1080p and 720p resolutions and H.264 compression
- ▶ 20x optical zoom and 16:9 image format enhance situational awareness
- ▶ Intelligent Video Analysis automates surveillance and threat detection



Bosch Security Systems introduces the AutoDome 800 Series HD high-speed pan-tilt-zoom cameras. With 360-degrees of coverage, the cameras provide superior optical resolution and day/night functionality, giving customers high-definition imaging in outdoor conditions. They solve a range of surveillance challenges for traffic and transportation applications, industrial sites, government facilities and parking garages.

A 1/3 inch progressive scan CMOS sensor gives customers 200x zoom (20x optical/10x digital) and HD imaging to make it easier to identify fine features in a scene, such as faces or license plates. 720p resolution at 60 images per second provides smooth, detailed video of fast moving objects. 1080p resolution at 30 images per second delivers six times the detail level of standard definition cameras, ensuring crisp video even when customers zoom in digitally to extend the camera's range. In addition, the 16:9 aspect ratio increases situational awareness by maximizing the field of view without compromising image clarity.

The AutoDome 800 Series HD Cameras include Intelligent Video Analysis (IVA) software that automatically processes video signals and alerts operators to

potential security risks. The higher pixel densities captured by the cameras enable optimized performance of IVA with improved detection for loitering, perimeter breaches and other potential threats.

With quad-streaming, the AutoDome 800 Series HD Cameras feature simultaneous streaming of high-quality video with differing frame rate and resolution settings for flexibility in system design. For example, customers can select 1080p or 720p HD video with H.264 Main Profile compression for live viewing and recording while sending JPEG images to a hand-held device.

For ease of use, 99 preset positions enable users to view critical monitoring areas with the touch of a button. The cameras also allow 24 privacy masks to ensure sensitive

areas cannot be seen.

The AutoDome 800 Series HD Cameras are designed to be simple to install. Pre-terminated, color-coded wiring and a quick connect system between the camera and mount make installation faster than other pan-tilt-zoom domes. The cameras also conform to the Open Network Video Interface Forum (ONVIF) standard, making them easy to integrate with other IP video equipment, regardless of manufacturer.

The heavy-duty, tamper-resistant aluminum housing is rated to IP 66 to provide uncompromised functionality even in dusty and potentially wet environments.

For more information on the AutoDome 800 Series HD Cameras, visit www.autodome.com.

CCTV

AutoDome 800 HD PTZ Camera wins prestigious award at SIA 2011 in Las Vegas



At the beginning of April the **AutoDome 800 HD PTZ Camera**, (the industry's first 1080p 20x PTZ), won the award for the *Best in Video Surveillance Cameras HD (Megapixel)* category at the Security Industry Association's (SIA) 2011 New Product Showcase (NPS). SIA's 32nd annual New Product Showcase was presented at the ISC West trade show held at the Sands Expo and Convention Center in Las Vegas on Wednesday, April 6.

The NPS Award is the most coveted recognition at ISC West and honors only the most unique and innovative security products on the market. Within the HD Video Surveillance Camera category, Bosch competed

against Arecont Vision, Avigilon, SAE Electronic Co., and Samsung. Overall, 85 entrants competed from 70 companies and 32 products from 30 categories were recognized by NPS awards.

Uncompromising Vision

The AutoDome 800 HD PTZ marks the next generation of AutoDome imaging solutions, bringing full high-definition resolution detail to the PTZ platform.

- **Faster identification with detailed images** - The 16:9 aspect ratio maximizes the field of view without compromising image details. 1080p resolution at 30 images per second or 720p resolution at 60 images per second provide more pixels per target object for a greater level of information and smooth video of fast moving objects.
- **Powerful optics** - An integrated 20x optical/10x digital zoom autofocus day/night camera delivers sharp images from long distances in outdoor environments.

- **Intelligence in motion** - Intelligent Video Analysis automatically processes video signals and alerts operators to potential security risks.
- **Designed for ease** - Pre-terminated, color-coded wiring and a quick connect system between the camera and mount make AutoDomes faster to install than other PTZ domes. ONVIF conformance provides compatibility with other IP video products.
- **Maximum flexibility** - Ninety-nine preset positions allow viewing of critical monitoring areas with the touch of a button.
- **Quad-streaming with H.264 compression** - Simultaneously stream high-quality images with different configurations. Select 1080p or 720p HD video for live viewing and recording while sending JPEG images to a hand-held device.
- **Vandal resistance** - A high-impact, tamper resistant aluminum housing rated to IP 66 delivers years of reliable operation even in dusty or wet environments.

Model Numbers:	
Part Number	Description
VG5-825-ECEV	800 Series HD, 1080p, D/N 20X CLEAR 50/60HZ, IVA
VG5-825-EDEV	800 Series HD, 1080p, D/N 20X TINTED 50/60HZ, IVA

CCTV

Bosch Extreme Environment Cameras secure open decks for Norwegian Cruise Line

The Challenge: Withstanding extreme weather on Norwegian Cruise Line (NCL)

For Norwegian Cruise line, it was difficult to find cameras that were able to withstand the type of extreme environments that their cruise ships found themselves in at times. "Our cruise ships must be able to withstand the storms – when wind can go up to 125 miles per hour. And we demand the same thing from the cameras that we install in the open deck areas." Samir Kljajic, Fleet Surveillance Manager of NCL explained. "Not to mention residual salt and galvanic transfer related corrosions," Mark White, General Manager of Empire Automation stated. "After years of developing anti-corrosion kits for various cameras the end result was disappointingly the same – the cameras lasted less than two years. Norwegian Cruise Line needed cameras that would help them monitor their open decks day and night even in the harshest conditions."

Bosch Extreme Environment Cameras: Get the job done even in the toughest environments

Mark White evaluated the Bosch cameras and discovered that the Bosch Extreme Environment cameras were able to meet NCL's wind and corrosion resistance requirements.

"We have been installing EX14 Bosch Extreme Environment cameras for years now on NCL cruise ships, and we have had no issues with them. Product reliability is the reason why we come back the Bosch Extreme EX14 cameras project after project."

Samir Kljajic cannot agree more: "Ever since we've bought the Bosch Extreme EX14 cameras, I haven't considered anything else to monitor our cruise ships' open decks. For our application, mainly monitoring open decks day and night, they are unbeatable."



Our Extreme Environment Solution

The Bosch Extreme Environment Cameras are all-environment cameras for harsh weather applications. EX14 Extreme Environment cameras' injection-molded ABS/Nylon resin is engineered specifically to withstand hot, cold, and wet environments. The cameras are weatherproof and IP66 compliant design for high-res image performance in the harshest environments.

Communications Systems

Bosch's display turns heads at ISE 2011

As in previous years, the Bosch Security Systems booth at ISE 2011 attracted a large number of visitors with its clear and structured setup and welcoming ambience. The booth impressed visitors with working demonstrations of all products on display (except for the CCS900 Discussion System) – more than any other exhibitor at the show.

As market leader for communication products, Bosch has been a regular contributor to the Integrated Systems Europe (ISE) exhibition since its beginnings in 2004. ISE is Europe's only dedicated exhibition and conference for AV and Electronic System Integrators, providing a unique showcase of technologies and solutions, supported by a comprehensive conference and education program. It attracts a host of visitors from the professional, commercial and residential markets, including architects, builders, consultants, designers, distributors, installers, IT professionals and system integrators.

This year's exhibition was the most successful AV and systems integration event ever held in Europe, with 715 exhibitors (150 more than in 2010) drawing 34,870 visitors, which was a 22% increase on last year.

At the Bosch booth, visitors were treated to demonstrations of the company's state-of-the-art conferencing systems, including the DCN NG with camera control and the DCN Wireless, plus new PC software for these systems, the Integrus Digital Infrared Language Distribution System as well as customized solutions. In addition, public address systems demonstrated included the Promatrix 8000, the Praesideo fully-digital Emergency Sound System and the Plena Voice Alarm system.

Visitors were also treated to demonstrations of a range of the

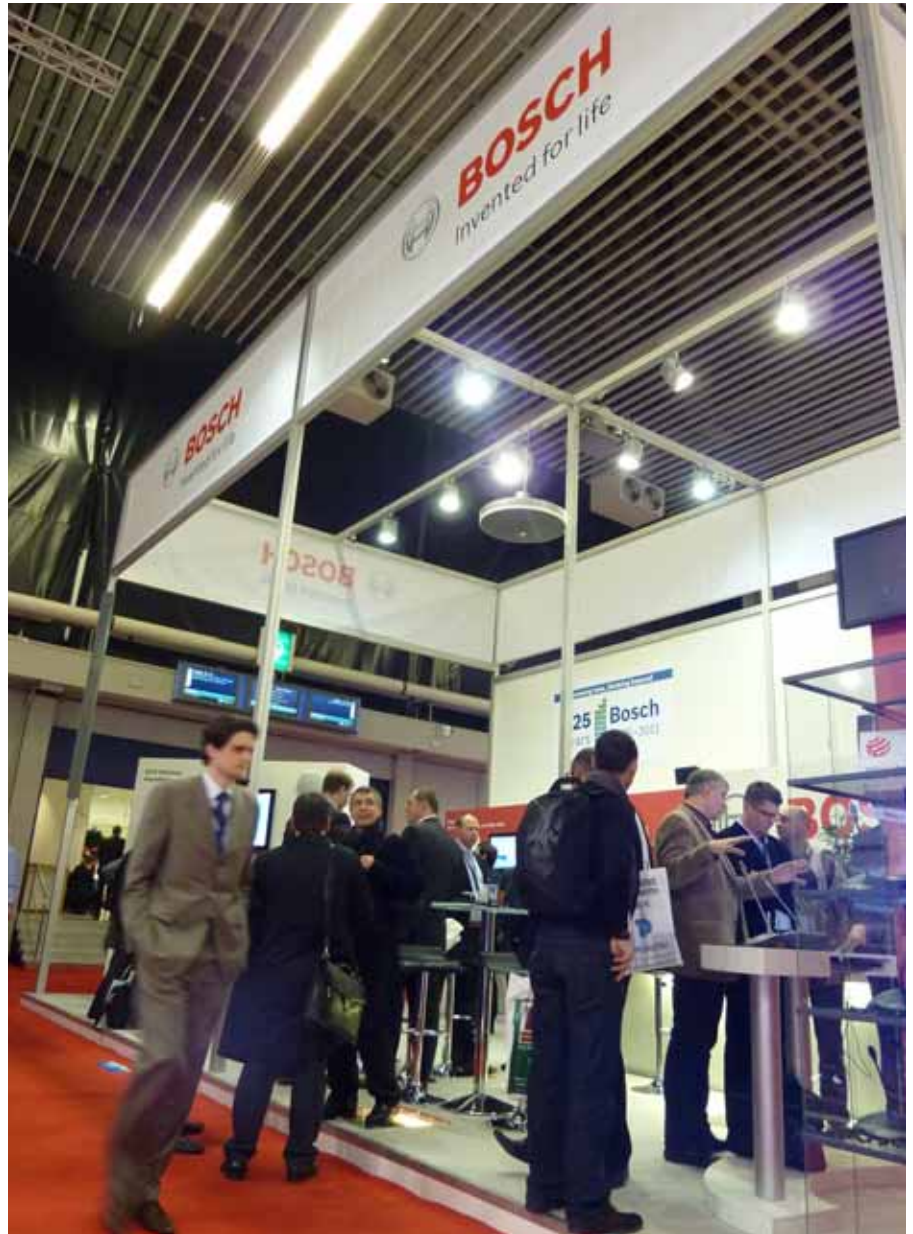

company's public address loudspeakers, the star being Bosch's new Vari-directional Array that combines unmatched sound quality with an evenly distributed sound pattern in difficult acoustical environments (such as railways

stations, airports and places of worship). The new Vari-directional Array has, moreover, recently won the prestigious InAVation award for the most innovative commercial loudspeaker of 2011.

Communications Systems

General Sales Support Organization endorses customized capabilities



'Custom-designed Product Solutions'-brochure with focus on the expertise to create a product with a different size, another appearance, or a different kind of function.



'Custom-designed Project Solutions'-brochure with focus on the expertise to manage even the most demanding projects and systems, no matter what the scale or level of complexity.

The Sales Support Specials Group is dedicated to find innovative ways to meet the needs of tailor-made conference and public address applications. For public address systems, the group has the knowhow to support a very wide range of applications, from PC call stations for cruise ships to rugged equipment for public transportation terminals and airports. In the area of conferencing, they specialize in complex applications, such as city councils, parliaments, and international organizations.

Bosch Sales Support Specials group wants to position the 'Custom-designed Product and Project

Solutions', as experts of custom-designed projects, systems and products.

When standard solutions simply aren't enough, this group of professionals, with its expert system architects and engineers, manage even the most demanding conference and public address projects. At every point in the project, from design to delivery and final installation, project management plays a key role, ensuring that everything goes smoothly. Each customized product is specially designed for a specific and unique application. Whether the change is aesthetic, functional, or both, these experts always takes a creative

approach. Whatever it takes to satisfy the requirements of the customer... alter buttons or replace them with dials. Change the color, the finish, the texture, or resize a unit to fit an existing piece of furniture.

The Bosch Marketing Communications department produced two brochures to assist the Sales Support Specials group in this endorsement. Without any expense, the countries will be given the opportunity to order these 2 English brochures by responding to the direct mailing send especially for this. If you miss this chance, you still can order these brochures (with a 50% price reduction) on the next Q-order.

Communications Systems

Intuitive Paging Call station for Praesideo system

The Sales Support Specials Group from Bosch Breda in The Netherlands designed a customized paging call station extension which is unique because of its intuitive character. This intuitive design gives the user a much easier and faster facility of starting announcements. In no time the user can make a decision selecting a specific area or decide for an all call.

The design is made by using so called membrane switches and corresponding indicators. The advantage of those devices is that they are available in many different colors and finishing. Which generate extremely freedom of design?

Membrane switches are versatile, use less space and are quality electromechanical switching components. They can even be used in high humidity and splash water environments. Graphics as legends, marks, symbols, company logo's are simple to be adopted onto the faceplate.

The picture below shows a complete paging call station with microphone and the intuitive call station extension. The design of the extension is typical for a sports stadium and has buttons with indicators for the North, East, West and South Side. Additionally it

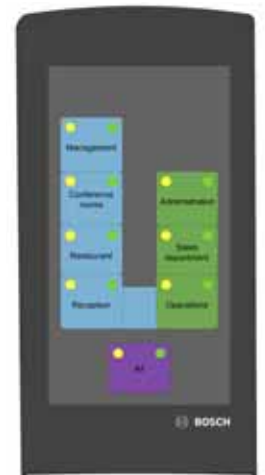

has in the middle of the four side buttons an 'All call' button for making announcement in all four sides at ones. Three standard buttons are available for general functions. The unit is meant to be used as table top unit and can be combined with customized and standard units. It easily fits at many places.

If you are also interested in such solution then you can contact the Sales Support Specials group from Bosch Breda in The Netherlands. They will take your idea into the design and

will show you how things looks like in such paging call station. You will be surprised what can be designed by the experts.

The drawing below shows such a paper design call station extension which has buttons for making announcements into the different departments. The button which is purple colored is the famous 'All call' function. Perhaps you like to see a unit with a unique company logo or unique text or both or perhaps in a flamboyant/flashy color.

Communications Systems

Convent of the Franciscan Sisters, Denekamp, the Netherlands

Speech intelligibility in a class of its own



Business area

Public address – public address and music installation

Sector

Churches

Location

Convent of the Franciscan Sisters, Denekamp, the Netherlands
The convent of the Franciscan Sisters in Denekamp can be found tucked away in green surroundings. The largest room in the Gravenhuis building was fitted out as the chapel, which is under the protection of Saint Nicholas because the parish church in Denekamp had Saint Nicholas as its patron. The 'Huize Noord Deurninghe' (Noord Deurning house) has since been named the St. Nicolaasgesticht (Saint Nicholas institution), which later changed to the St. Nicolaasstichting (Saint Nicholas foundation). A small chapel was built in 1896, and this was extended in 1934 and subsequently adapted several times. The Saint Nicholas foundation is home to around 120 sisters, spread over the five buildings on the site. The Huize Elisabeth and Franciscushuis buildings

are centers for contemplation and meeting together, and they are used by the sisters and by church and community groups involved in people's welfare.

Aim of the system

The AV system for the convent needs renovation and it must be operated by a simple interface. The new loudspeakers must comply with the following requirements:

- They must broadcast speech/music
- They must be clear and intelligible
- They must be practically invisible to churchgoers
- They must have a simple interface

Solution

A Vari-directional loudspeaker combined with third-party equipment was chosen to ensure that the sisters can operate the system themselves. The Vari-directional loudspeaker with high-quality music playback (LA3-VARI-BH) was chosen because this active loudspeaker is intended for both background music and speech. Many modern and historic buildings, such as the chapel of this convent, have floors,

walls, and ceilings made of hard materials that reflect sound. Their heights and the absence of absorbent materials means that the sound reflects for a long time and there is a high level of indirect sound compared to direct sound. This is disastrous for good speech intelligibility. The modular design makes three different array lengths possible for spaces ranging from small to large. Separate array elements are used so that the array is easy to transport and the length of the array can be expanded simply. The Vari-directional array creates an excellent level of sound quality and speech intelligibility.

Result

The music and public address system complies with the requirements that were set initially. The sisters are extremely happy with the end result and the simple interface allows them to operate the system themselves.

Installed by

Hecla Professional Audio & Video Systems, Hengelo, the Netherlands

Communications Systems

EVAC system from Bosch in exhibition halls at Kielce Fair

Industry

Exhibition and Congress Center
Exhibition halls at Kielce Fair

End User

Kielce Fair is the second greatest trade center in Poland. It has the second largest own trade fair area. The fair also offers a broad portfolio of services like organizing conferences – including international ones. With an almost 30% share in the Polish trade fair market in 2009, it is the most dynamically growing exhibition facility in Poland. About 60 trade fair events are organized each year and in the last three years, the Fair was visited by over 415,000 people. Until 2013, Kielce Fair will be expanded and modernized.

Exhibitors will have access to a new exhibition area as well as a modern Congress Center.

Business Objective

EVAC project author: Mr Tomasz Chyb, Msc., Eng. (System Project, Kielce).

The task of the design company consisted of developing a sound system with an evacuation function (EVAC) for the exhibition halls E and F at Kielce Fair.

At the moment, a new EVAC installation for G hall is in the design phase and it is planned to build EVAC in another 4 halls: A, B, C and D as well.

Solution

The implemented EVAC system is based on Bosch Security Systems solutions. Sound is delivered to exhibition halls through hemi-directional loudspeakers 100W



E Hall at Kielce Fair

each, placed below the ceiling. Thanks to specialized simulation of the acoustic conditions in each hall, the location of each loudspeaker has been precisely indicated. In total, 14 hemi-directional loudspeakers have been installed in the E and F halls. The administration part is covered with certified ceiling speakers and sound projectors. All loudspeakers are powered and controlled by the Praesideo digital sound system. The system is operated through microphone call stations placed in the halls' reception.

Result

Two exhibition halls at Kielce Fair are equipped with a Bosch Praesideo digital sound and voice evacuation system which meets the investor expectations with regard to functionality in such a complex facility. The use of hemi-directional loudspeakers enabled the creation of a professional sound system with superior sound quality for both commercial and sound evacuation purposes.

The total exhibition area which will eventually be covered by the EVAC system amounts to approx. 40,000 m².

Communications Systems

Greece's first Vehicle Museum to open to public in March



Vehicles like actor Paul Newman's Mercedes 300 SL Gullwing, legendary Led Zeppelin rock group frontman Robert Plant's 1959 Chrysler Imperial, Formula 1 driver Lorenzo Bandini's personal 1953 Lancia Aurelia with its Gucci-designed interior will be on display at Greece's first Vehicle Museum that opened its doors in March.

The complex is equipped with a Bosch Praesideo public address system driving some 400 speakers inside the museum and the amphitheater. The amphitheater is also equipped with a Bosch DCN conference system and an Integrus wireless language distribution system. Both systems are connected so in the event of an emergency all people in the building will immediately be informed about the incident.

The recently inaugurated Museum, located in a multi-purpose cultural, commercial and recreational facility in Athens, features a number of 111 cars belonging to historical figures of the arts and politics. The facility, which also contains a conference center, a 3D cinema, some 30 shops, and 10 restaurants and cafes, as well as an underground garage is expected to attract more than three million visitors annually.

Communications Systems

Vari-directional Array from Bosch wins prestigious InAVation Award

Most innovative commercial loudspeaker of 2011

- ▶ Unmatched sound quality in difficult acoustic environments
- ▶ Evenly distributed sound pattern over ranges up to 50 meters
- ▶ Intelligent configuration software allows fast installation

Bosch Security Systems' new Vari-directional Array has won the 2011 InAVation award for the most innovative commercial loudspeaker.

The prestigious awards are presented annually to global manufacturers introducing commercially available



From left to right: Martijn van Overveld (Bosch Security Systems), Michel van Loon (Bosch Security Systems) and Richard Lawn (Pro Audio Middle East)



products into the EMEA market. The winners for this year's awards were announced on February 2, 2011 at the InAVation Awards Ceremony held at the Amsterdam RAI Diamond Lounge. The award for the most innovative commercial loudspeaker was presented by Richard Lawn from Pro Audio Middle East. Accepting the award on behalf of Bosch were Michel van Loon, Acoustic Application Specialist for Public Address EMEA, and Martijn van Overveld, Product Marketing Manager for Public Address EMEA.

The Vari-directional Array was developed by Bosch to produce unmatched sound quality and superior speech intelligibility in difficult acoustical environments such as railways stations, airports and places of worship. A key feature of the array is its digitally-controlled directivity which ensures that sound is sent only where it's needed to produce optimal sound distribution and audience coverage without wasting output energy on ceilings or empty space above the audience.

Active line arrays like Bosch's Vari-directional array offer many advantages such as large coverage and less installation effort. A drawback of many of today's active line array designs, however, is that the generation of the perfect sound beam often needs to be done by trial and error. Bosch has addressed this issue with proprietary configuration software that uses a database of pre-programmed room settings to fit any acoustical environment. The installer just enters the room dimensions and requirements and the software does the rest. The result is a quickly installed loudspeaker system with consistent, high-quality sound reproduction.

With their sleek design the arrays fit unobtrusively into any surroundings. They are also fully EVAC compliant which makes them the perfect fit for voice-alarm applications.

Communications Systems

Bosch receives EN 54 certification for all of its voice alarm systems and components

- ▶ Certification granted by accredited notified bodies
- ▶ Fully integrated EN 54 certified fire alarm and voice evacuation solutions for every application
- ▶ EN 54-24 certified products available for the full range of audio applications

Munich - Both of Bosch's voice alarm systems – the mid-end Plena system and the high-end fully digital Praesideo system – have been granted EN 54 certification by accredited notified bodies. Certification includes not only the central voice alarm equipment but also peripheral equipment such as loudspeakers.

Bosch Security Systems has long been a leading supporter of international standards for security equipment and was one of the first companies in the world to champion the new EN 54 standard for voice alarm systems. Originally introduced as a European standard for fire alarm systems, EN 54 has now been extended to cover voice evacuation to meet a growing trend in the market towards integration of fire alarm and voice evacuation systems. The standard covers three important equipment areas of voice evacuation: EN 54 16 for central voice alarm control and indicating equipment, EN 54-24 for loudspeakers and EN 54-4 for power supply equipment.

By the beginning of 2009 Bosch had already presented to the market the first EN 54-16 compliant voice alarm system. Thereafter, to gain certification for all its evacuation systems by an accredited notified body as required by April 2011, the company worked with multiple accredited bodies to certify voice alarm equipment. As a result of these actions, Bosch can now announce that all components of its voice evacuation systems have been granted EN 54 certification by these accredited laboratories. The Praesideo 3.5 and Plena VAS 2.16 central equipment have received certification to EN 54-16. Bosch also supplies charging equipment certified to EN54-4, and the company has been granted



EN 54-24 certification for a broad range of loudspeakers covering a host of different application areas associated with voice EVAC. In contrast to other manufacturers, who offer only loudspeakers for one or two defined applications, Bosch can provide EN 54-24 certified products for the full range of audio applications, including voice alarm, speech and background music as well as foreground music and professional audio. The range includes indoor and outdoor loudspeakers as well as flush-mounted loudspeakers for walls and ceilings.

With EN 54 certification of its voice alarm systems and components as well as its Fire Panel 1200 Series and Fire Panel 5000 Series, Bosch can now offer fully integrated EN 54 certified fire alarm and voice evacuation solutions for every application to provide optimum protection for the public and personnel.

EN54-4	EVAC Certified Emergency Voice Alarm
EN54-16	EVAC Certified Emergency Voice Alarm
EN54-24	EVAC Certified Emergency Voice Alarm
EN54	EVAC Certified Emergency Voice Alarm

Communications Systems

Dubai International Airport is home to world's largest Praesideo Public Address and Emergency Sound System from Bosch



With more than 120 Active Line Arrays, 3500 ceiling speakers, 250 sound projectors and 400 XLA Line Arrays, the extension of Dubai International Airport with Terminal 3 and Concourse 2 is a huge Praesideo-controlled installation. All these speakers are driven by more than 300 amplifiers interconnected with 125 Cobranet units in a single system controlled by 44 Network Controllers in a redundant configuration that is fully EVAC compliant.

Moreover, it is just what this absolutely no-compromise, high-quality customer experience demanded for the main hub of the United Arab Emirates' main carrier: Emirates

Airline. Terminal 3 is perhaps the most powerful example yet that Dubai International Airport is totally committed to comfort, style and professionalism.

The heart of the system

The central control of this system consists of a software application provided by the Building Information System (BIS) from Bosch. It is the heart of the system that takes care of central logging, redundancy handling, PC call-station functionality and the interfacing to the automatic announcement system, as well as other airport systems such as the fire alarm, flight information and building management systems.

Innovative thinking

Given the size of this project, new ways of designing, logistic processing and shipments needed to be developed on the fly. For the special architecture of this airport, the German company Rahe-Kraft was subcontracted to provide an optimal acoustic design to meet the customer's specifications. This was proven during a successful trial period that ended in October 2010.

With Dubai International Airport, Bosch truly has completed an immense project and gained a great deal of useful experience to be shared with its partners.

Communications Systems

DCN from Bosch in the Norwegian Parliament 21st century technology discretely integrated into historic interior architecture



DCN (Digital Congress Network) Interactive solution provides the Norwegian Parliament with faster voting processes and superior sound.

When Norway's Members of Parliament (MP) returned to their desks after the 2010 summer recess they were pleasantly surprised by their refurbished chamber. The old-fashioned desktops were gone - replaced by more ergonomic, more efficient work stations. And the chamber's sound system had been radically upgraded for increased sound quality.

All this was achieved without altering the chamber's distinctive character, its atmosphere of history and heritage.

This subtle make-over had become necessary because the whole business of tabling motions, managing debates and reporting on voting results had become slow and inefficient. Not all MPs could be heard clearly throughout the chamber - which had gradually increased its number of seats over the years. What's more, any changes to the order of the day's business couldn't be easily distributed during a session, and members were forced to wait several minutes for votes to be counted and announced before they could move on to other business. On top of all that, none of the MPs had access to the information networks they needed during debates.

Now all that has changed, thanks to one of the most advanced discussion and voting systems in the world - the DCN Interactive Discussion System from Bosch. Each MP now has a touch-screen monitor, voting button, microphone and loudspeaker in the desktop. The screen displays not only voting results the instant that votes are cast, but also the day's agenda, members who are tabled to speak, and how much speaking time is remaining. The touch-screen also links to further information, for example, details about the member currently speaking. And USB connections allow other electronic devices to be added. In addition, the new desktops include microphones, headphones and

loudspeakers – enabling members to address Parliament from their own desks.

All of which means that MPs are better informed and can more easily and more quickly contribute to debates. Everything is smoother, faster and more productive. The system has already received praise from its users, and the number of three-minute speeches has dramatically increased because the system makes it easier to request and schedule them.

Everybody pleased

“Everybody is very pleased with the result,” says Arild Øverby, senior engineer and project manager for the ICT section of the Norwegian Parliament. “We not only wanted better sound quality, we also wanted to be able to distribute changing information to MPs at their desks, and to enable them to access other important data.”

Bosch supplied the sound and voting system through its partners

Siv.ing. Benum AS, who installed all the devices and cabling, and ensured that the chamber retained its unique character by keeping everything out-of-sight. “We first wanted to create our own solution for the desks,” says Arild, “But Bosch and its partners proposed something very special. Their design was so compact and thoroughly thought out, that we went for it almost immediately.” The design was tested extensively to ensure that the cables, monitors and sound equipment could be placed without conflicting with the requirements from the Directorate for Cultural Heritage.

Everything integrated

The cables for all electronic systems are placed in the sidewalls. The complete system is connected to a Central Control Unit (CCU) which digitizes all incoming signals via software specially developed by Bosch. The CCU is also connected to the Parliament building’s own network by means of tailor-made software developed by Cap Gemini. In this way, everything is integrated into one system. A thin client is connected to each MP’s desk, but is invisible. Also part of the delivery is a special website, where members of the public can follow the work being done in the Parliament.



Communications Systems

CCS 900 Ultra Discussion System from Bosch wins 2010 GOOD DESIGN Award

System combines innovative elegant design with superior acoustical performance

- ▶ New elegant styling complements any interior
- ▶ Superior sound quality optimized for speech
- ▶ Innovative meeting-management features

Munich - Bosch Security Systems' new CCS 900 Ultra Discussion System has won a prestigious GOOD DESIGN Award.

The award is conferred annually by The Chicago Athenaeum: Museum of Architecture and Design and The European Centre for Architecture Art Design and Urban Studies in recognition of products displaying 'visionary and innovative concepts, invention and originality'. Founded in Chicago in 1950, GOOD DESIGN is the oldest and one of the most sought-after awards recognizing design excellence, and attracts submissions from design firms and manufacturers from all over the world.

Designed for small to medium sized meeting, the CCS 900 Ultra discussion system from Bosch combines new elegant styling that complements any interior with superior speech intelligibility. It also boasts innovative features which make it easier to manage meetings. These include an advanced patent-pending 'Possible-To-Speak' function that gives a visual indication of when the microphone is available for a delegate to take the floor. The system's Control Unit can record and play back up to 64 hours of discussion on a 2 GB SD card, and it features a 60 second buffer enabling the SD card to be changed when full to allow recording to continue without losing any data. The delegate and chairman units include a built-in loudspeaker, a microphone that's activated with a single touch and two headphone sockets with volume control.



In addition, four easy-to-use operating modes give the CCS 900 Ultra added versatility for more focus on the conversation. During meetings, one to four microphones can be active simultaneously, with the chairman always having speaker priority. And to support external participants (during town-council meetings, for example),

extra microphones in any style (wired, wireless, handheld or podium) can be connected to the system.

Since the CCS 900 Ultra is a plug-and-play, all-in-one discussion solution, it requires no special training to operate it. Anyone can begin using the intuitive controls immediately.



Communications Systems

German Chancellery installs conference system from Bosch



The German Chancellery in Berlin has chosen once again to install state-of-the-art conferencing equipment from Bosch. The recently renovated 'small cabinet room' has been equipped with a new DCN Next Generation conference system featuring stylish custom-made delegate units created by Bosch in cooperation with the Chancellery.

Bosch is no stranger to the German Chancellery. In 2008, a DCN Next Generation system with 130 Centurus delegate units and an Integrus Digital Infrared Language

Distribution system was installed in the Chancellery's 'Nato Room'.

Now, based on its good experience with this earlier system, the German Chancellery also chose to use innovative and reliable Bosch equipment for the 'small cabinet room'. The room is used exclusively for international state and ministerial meetings, and the new custom-made elliptical table which seats 26 people called for a quality custom-made conferencing system that would perfectly complement the distinguished character of the room and table.

The new DCN Next Generation system comprises 26 stainless-steel flush-mount units featuring a microphone, a microphone control unit, a channel selector and a cover, through which VGA cables for the mobile projector can be fed, thus avoiding messy trailing cables on the table.

Three interpreting booths fitted with DCN Next Generation Interpreter Desks and a technical room have also been permanently installed in the cabinet room.

Communications Systems

DYNACORD's PROMATRIX 8000 combines ProAudio with public address & voice evacuation

- ▶ Best scalable solution for venues requiring permanent public address, EVAC and professional sound functionality
- ▶ High-quality digital sound surpassing the performance of many professional sound systems
- ▶ IRIS-Net™ control and configuration enabling highly customized audio and control throughout the system.

Straubing, February 2011 DYNACORD, leading manufacturer of professional audio systems, introduces the PROMATRIX 8000 system, combining audio reproduction at a professional level with reliable public address and voice evacuation functionality.

Venues where professional sound and public address/voice evacuation functionality are both required commonly have to rely on separate systems. The new PROMATRIX 8000 eliminates the need of two separate systems created by this approach by providing a unique integrated, single solution for medium to large venues where permanently installed public address and voice evacuation are required with additional professional audio functions. Examples of such venues include stadiums, hotels, casinos, universities, sports and leisure facilities and office buildings.

By integrating both functions in just one system, configuration and setup are highly efficient and cost-saving. The PROMATRIX 8000, moreover, meets all relevant safety standards. It can also act as a standalone public address and/or voice evacuation system.

Professional audio quality

Featuring advanced digital signal processing, the PROMATRIX 8000 system delivers truly impressive audio with a signal-to-noise ratio of 105 dB, surpassing the performance of many professional sound systems and the



sound requirements of live concerts. In addition, multi-channel audio routing and multiband equalization on the fly ensures that customized audio is available throughout the installation.

Flexible and reliable emergency evacuation

The heart of the PROMATRIX 8000 system is a digital network controller that takes care of audio routing and handling of control data. The controller offers digital audio processing and has eight slots for input and output cards, enabling it to connect to call stations, music sources such as CD players, and stored-message systems. Multiple controllers can be networked to create large application solutions that can feed up to 1000 zones with pre-recorded messages, live speech and/or music.

In addition, control I/O modules for integration of other external functions can easily be inserted into the system. These can, for example, control pan/tilt functionality of a video camera,

activate emergency lighting, trigger sun-screen open or closure and operate entrance control systems.

The entire system network, whether local or de-centralized, is configured and controlled via IRIS-Net™ software, enabling highly customized audio and control throughout the system.

To assure safe operation at all times, the system is fully supervised from paging station to the last loudspeaker in the line. The system also incorporates 24 V power to connect backup power sources in case of a main power source failure.

The PROMATRIX 8000 is a comprehensive and complete system that offers an extremely high level of functional integration. It also offers the flexibility to easily integrate third-party equipment such as Electro-Voice equipment, as well as DYNACORD low-Z amplifiers. Once configured, standalone and networked systems can operate without a PC connected.

Communications Systems

Speed skating world championships with DYNACORD and Electro-Voice

- ▶ In March 2011, the new Max Aicher Arena in Inzell opened in style with the speed skating Single Distances World Championships
- ▶ The arena boasts a state-of-the-art sound reinforcement and evacuation system from DYNACORD and Electro-Voice
- ▶ The technical planning and installation of the sound system were performed by TRE Professionelle Audiotechnik of Parkstetten
- ▶ Systems from Electro-Voice were also used in the venue's Party Zone



The Max Aicher Arena in Inzell was the setting for speed skating's Single Distances World Championships, which ran from the 10 to the 13th March

Inzell / Straubing, March 2011 – The new Max Aicher Arena in the Bavarian resort of Inzell recently celebrated its grand opening with the Single Distances World Championships in speed skating, which ran from March 10-13, 2011. Work on the conversion of the old open-air stadium into the futuristic indoor arena that graces the site today began in September 2009 and cost 36 million Euros.

The Parkstetten-based firm of TRE Professionelle Audiotechnik was responsible for the installation of the sound reinforcement system in the thoroughly renovated stadium. A complex task, since in addition to the low ambient temperatures inside the new hall, the architecture of the building made the high level of intelligibility demanded by the client a tricky objective to attain. "The system we were asked to provide had to offer homogeneous and high-quality sound reinforcement as well as multiple input stations," explains TRE Managing Director, Robert Ernst. "Furthermore, the complex had to be subdivided into discrete sound reinforcement segments."

optimal loudspeaker positions but also the models best adapted to occupy them. "It became clear that loudspeakers from DYNACORD and Electro-Voice were capable of outperforming their competitors by a wide margin, as well as offering far better value for money," reports Ernst. Many years of experience with DYNACORD and Electro-Voice in the field of stadium sound reinforcement, along with a long list of prestige related references worldwide, spoke eloquently in their favour.

To provide even coverage throughout the new complex, eighty-nine Electro-Voice Sx600 loudspeakers were installed. These were powered by twelve DYNACORD DSA amplifiers (8 x 500 W in each case). "The acoustic properties and weatherproof cabinets of the Sx600 loudspeakers have already vindicated their selection in numerous similar venues," explains Ernst. "But our personal favourites in this installation are the powerful DYNACORD amplifiers, which are remarkable for their compact format, low closed-circuit current and excellent audio characteristics."



A total of eighty-nine Electro-Voice Sx600 loudspeakers provide sound reinforcement in the new 6,000-seater arena

With the help of simulation software, TRE's planners were able to determine the ideal loudspeaker configuration for the arena: in other words, not only the

The solution adopted in Inzell, as in many other modern sports stadiums and arenas worldwide, is a combined sound reinforcement (for musical

material) and voice alarm system (for evacuation in case of emergency). In Robert Ernst's view, this is not only the "most appropriate solution these days", but also one that is user-friendly and offers in this case – thanks to the quality and design of the components used – maximum security and reliability. "The supervision of the individual components afforded by this solution makes everyone's job a lot easier," Ernst explains. The centerpiece of the digital evacuation and voice alarm system, tried and tested in countless major installations worldwide, is the DYNACORD Promatrix 4000 – a failsafe solution that continues to function reliably even if the mains power fails. The control and supervision of the entire audio installation is performed by two DYNACORD P64-1500 audio system controllers.

Party Zone with MSE Tontechnik – and Electro-Voice

Whilst inside the arena over 6,000 fans were celebrating Jenny Wolf's victory for the fourth year running in the 500-metre sprint, thousands more were following the event on a giant screen in the Party Zone outside. The sound reinforcement here was the responsibility of the Stubenberg-based audio firm of MSE-Tontechnik. Some



High technology in the snow: the new Max Aicher Arena in Inzell



In the Party Zone, too, visited by 20,000 revellers...



... it was Electro-Voice that set the tone

20,000 sports fans visited the Party Zone at some stage in the course of the event, where an active three-way system had been installed, comprising Electro-Voice XLD281 line-array elements, flown Electro-Voice XS212 subwoofers and ground-stacked Electro-Voice Xsubs to reinforce the low frequencies. These were complemented by Xi1152A/64F loudspeakers for the near field. The entire installation was powered by Electro-Voice TG7 power amplifiers equipped with RCM26 modules, remote-supervised and controlled from the FOH position via IRIS-Net. "In spite

of the cold," reports MSE Managing Director Johannes Schilling, "not a single component failed throughout the entire event. Everything worked perfectly. The new IRIS-Net V2.0 preset for the XLD loudspeakers proved particularly useful, convincing us right away."

For further information, visit: www.dynacord.com and www.electrovoice.com

Communications Systems

NEP Visions equips new OB trucks with the MADI-16 Plus card from RTS/TELEX

- ▶ The British broadcasting service provider NEP Visions has integrated the MADI-16 Plus card from RTS/TELEX into its new OB trucks, Gemini 1 and 2
- ▶ The card connects the ADAM frames to the trucks' audio consoles
- ▶ Via coaxial and fibre connections up to 64 I/O channels can be scaled for all AES-10-compliant devices



Staines / Straubing, April 2011 – Based in Staines (Middlesex), NEP Visions has been covering major sporting, cultural and social events for over 25 years. In fitting out its new 3Gb/s OB vans, Gemini 1 and 2, the independent outside broadcast service provider opted once again for systems from RTS/TELEX: flawless communication is ensured by a 196 x 196 ADAM matrix with fibre-linked TBX-Tribus expanders. Through the integration of the MADI-16 Plus card, the intercom system can now be linked with the OB vans' two Calrec Apollo digital audio consoles.

Via coaxial or fibre connections, up to 64 I/O channels can be scaled with the MADI-16 Plus card for all AES-10-compliant devices. In its basic configuration, the card permits the integration of 16 digital audio I/O channels of a MADI stream. The number of audio channels can be increased in steps to sixty-four by software upgrade. The card operates with sampling rates of 44.1 or 48 kHz and is equipped with Wordclock and TV-Sync inputs, whilst the MADI connection is implemented via BNC or LC plugs on the connector panel.

Explaining why for over ten years now the company has opted consistently for systems from RTS/TELEX, Paul Fournier, NEP Visions' Head of Sound says: "The systems from RTS/TELEX

Premier and Champions League football are only a few of the events covered by NEP Visions, which has been relying on RTS/TELEX equipment for 15 years



The KP-32 keypanel

have proved their reliability over many years. Furthermore, the overwhelming majority of freelance sound engineers are very familiar with them. They can all program the systems without any

problems. That makes our job considerably easier."

NEP UK's fleet of outside broadcast vehicles now includes fourteen HD,



Visions is the largest independent broadcasting service provider in the UK, boasting a fleet of 15 outside broadcasting vehicles

six SD and six VT trucks. The UK group also offers studio solutions in Cardiff. Among the high-class events NEP Visions has covered recently are Wimbledon, the Cheltenham Festival, the British Open (golf), Hard Rock Calling and T In The Park. Additional projects included the Pope's Visit to the UK as well as the Ryder Cup.

Managing Director Steve Jenkins is extremely proud of the two new editions to NEP Visions' outside broadcasting fleet: "The challenge was to move Outside Broadcasting forward, and to provide a feast of

technological innovation and power framed in a new and exciting truck design. Great credit to the team here at Visions who have worked tirelessly to realise an answer to that challenge. Gemini 1 and 2 are what superior technical design is about; they encapsulate the future and provide a fantastic addition to the NEP Visions fleet, they are capable of withstanding the demands of any OB asked of them."

For further information, visit: www.rtsintercoms.com



The Madi-16 Plus card

Communications Systems

FIS Nordic Skiing World Championships in Holmenkollen with systems from Electro-Voice



Electro-Voice loudspeakers provide sound reinforcement for the newly designed National Arena in Holmenkollen

- ▶ Competition venues at the Nordic Skiing World Championships 2011 were equipped with loudspeakers and power amplifiers from Electro-Voice
- ▶ The project was realized by the Norwegian firm Scandec Systemer AS
- ▶ Over 300,000 visitors followed the progress of the competitions in the Oslo suburb, along with millions more on television

Oslo / Straubing, March 2011 – The Holmenkollen neighbourhood of Oslo, a venue with a rich sporting tradition, played host to the World Nordic Skiing Championships from February 24 to March 6, 2011, and event organized by the International Ski Federation (FIS). According to the organizers, around 300,000 fans attended the various competitions, with millions more following the event on television. With more than 650 athletes from over 60 different countries competing and around 2,000 representatives of the media in Norway to cover the event, this was one of the largest sporting events on record. With medals disputed by both men and women in over twenty disciplines in the categories Ski Jumping, Cross-Country and Nordic Combined, and a lavish

fringe programme of cultural events in and around the newly designed National Arena in Holmenkollen as well as in downtown Oslo, visitors had no excuse to be bored.

To enhance their appreciation of the competitions as they unfolded, the firm of Scandec Systemer AS was commissioned to install new sound reinforcement systems at the foot of both the large Holmenkollbakken ski-jump and its smaller companion, the Midtstubakken, as well as the Langrennsarenaen, from which the skiing events were observed. In the planning of the sound design, the company based in nearby Kolbotn worked closely with Norwegian television broadcaster NRK to ensure not only that the new system

represented a convincing sound reinforcement solution for speech, jingles and music, but also that the loudspeakers did not obstruct lines of sight for the cameras.

In all, some 250 loudspeakers were distributed between the three competition venues. Among them were 56 ZX1i composite indoor/outdoor two-ways and weatherproof representatives of the EVF range in the shape of fifty-one EVF-PIB and the same number of EVF-1121S-PIB cabinets, each equipped with a 12-inch woofer. The criteria determining the choice of speakers were their frequency response, sound pressure levels, coverage patterns and robustness, the extraordinary imperviousness to adverse weather conditions of the Electro-Voice models selected proving one of their trump cards. Electro-Voice power amplifiers with a total output of 120,000 watts RMS were enlisted to drive the speakers, the task falling to thirty-four CPS 8.5 amps. The entire system was controlled by twelve digital signal processors. A fully digital and redundant solution was also found for the signal transmission via Ethernet using the CobraNet protocol.

The installed loudspeakers can be turned on and off individually using touch screens, so the system can be adapted, now that the world championships are over, to future events.

Equipment list (extract)

56 x EV ZX1i

51 x EV EVF-PIB with various horn patterns

51 x EV EVF-1121S-PIB (1 x 12" driver)

34 x EV CPS 8.5 power amplifiers

For more information, visit www.electrovoice.com



The arena was the setting for the FIS Nordic Skiing World Championships, which ran from the 24th February to the 6th March 2011



At various venues within the EV-equipped National Arena medals were disputed in the categories Ski Jumping, Cross Country and Nordic Combination



The Electro-Voice loudspeakers provided a convincing sound reinforcement solution without obstructing lines of sight for the TV cameras

Communications Systems

Electro-Voice triumphs at the FIS World Skiing Championships 2011



Stages at strategic locations throughout Garmisch-Partenkirchen treated visitors to a lavish programme of entertainment – with Electro-Voice ever to the fore

- ▶ Well over 100,000 fans attended this year's World Skiing Championships in Garmisch-Partenkirchen, with millions more following the event on television
- ▶ Sound reinforcement in the central Medal Plaza was provided by XLVC line arrays driven by CPS and TG7 amps from Electro-Voice
- ▶ The technical planning and execution for the downtown events was the responsibility of TC Showtechnik of Weilheim

Garmisch-Partenkirchen / Straubing, March 2011 From February 7-20, the resort of Garmisch-Partenkirchen in Bavaria was overrun by some 100,000-plus fans attending the 2011 edition of the FIS (or Fédération Internationale de Ski) World Championships. In addition to spectacular races, visitors were treated to a varied programme of entertainment that more than justified the organizers' claim that – far more than simply a sporting event – Garmisch-Partenkirchen was offering visitors a 'festival in the snow'. Medal Plaza, for instance, in Michael Ende Park, was the scene each evening not only for the presentation ceremonies but also for shows featuring top German and Austrian acts like Ich + Ich, Culcha Candela, Christina Stürmer and DJ Ötzi, each drawing audiences of up to 4,000 fans at a time.

As was the case at last year's finals of the skiing World Cup, not only the races but also the organisation and

logistics of the event were subjected to the closest possible scrutiny, the reason being that Garmisch-Partenkirchen is currently bidding together with Munich to host the Winter Olympics in 2018. Not only the athletes, therefore, but the entire organizational committee and all service providers were anxious to be seen in the best possible light. Prominent among the latter, naturally, was the team from TC Showtechnik of Weilheim, which was responsible for the lighting and sound reinforcement in a number of key event locations including Medal Plaza.

Celebrating with Electro-Voice XLVC The centrepiece of the sound reinforcement design was the XLVC line array from Electro-Voice. "We used EV's LAPS line-array simulation software to ascertain the ideal set-up for the event," reports Martin Schulze, who manages the Bavarian rental company jointly with Stefan Rehtaler.



Electro-Voice line arrays convinced even the most critical FOH men and their bands

for engineers – via Electro-Voice’s IRIS-Net – to intervene promptly wherever necessary to adjust the output or frequency response of the system. But it is not simply the sound processing but also the routing possibilities afforded by the N8000-1500 controller that Schulze cherishes. “I know of no device with which you can work more creatively,” he says. “With it, you can really construct the perfect matrix.”

Not only the technicians, of course, but the material itself at the World Skiing Championships was subjected to severe stress; but despite the most adverse weather conditions, with temperature variations in excess of 20 degrees Celsius, not one single component failed throughout the entire fortnight. “Once again, systems from Electro-Voice have proved that they are entirely impervious to cold, rain, snow and even ice,” concludes Schulze.

Fixed installation on the new Kandahar downhill run

Two years ago, the team from TC Showtechnik installed a sound reinforcement system along the newly designed, three-kilometre Kandahar downhill. The solution here involved mounting some thirty-four CD850 loudspeakers from Electro-Voice on iron masts up to 14 metres high lining the run. “For my money, these are not only the most robust 100-V loudspeakers on the market,” says Schulze, “but also systems offering outstanding sound quality and intelligibility.” On the Kandahar run, the loudspeakers are driven by six channels of power emanating from Electro-Voice CPS 4.5 amplifiers.

For more information, visit www.electrovoice.com



A ‘festival in the snow’ - Medal Plaza was the scene not only of the presentation ceremonies but also of concerts, with the sound reinforcement in each case provided by Electro-Voice

“Even habitually critical FOH engineers working here with their bands expressed their extreme satisfaction with the system.”

The main array in Medal Plaza consisted of twelve EV XLD281 cabinets per side complemented by flown XCS312 cardioid bass elements to enhance the lower midrange. To boost the very bottom end, twelve EV Xsubs were positioned beneath the stage. To provide homogeneous coverage for all 4,000 listeners, eight Electro-Voice XLE loudspeakers plied those at the very front of the audience as well as to the left and right of the stage with near-, in- and out-fill, as appropriate. The XLD hangs were driven by 16-channel amp racks made

up of two Electro-Voice CPS 4.10 amps and one CPS 8.5 amp each.

“This allowed us to drive in each case three stacks actively in three-way mode, thereby achieving considerably greater acoustic differentiation,” explains Schulze. The subwoofers were driven by EV TG 7 power amplifiers, whilst foldback to the performers on stage was provided by side-fills comprising Electro-Voice’s tried-and-tested MT2 bass elements combined with PX1122 tops and PX1152 wedges, with the entire monitoring system powered by CP3000S amps. Meanwhile two Electro-Voice NetMax N8000-1500 digital matrix controllers employing FIR-Drive technology made it possible



A team from TC Showtechnik led by Martin Schulze was responsible for both the planning and the implementation of the sound reinforcement design

Fire

Technical Training in Grasbrunn with an eye towards Poland

Let's kick it SAFELY

How to deal with a large football stadium project



One Team, one Trainer, one National Stadium: if you think we are talking about soccer, it is only half the truth! What actually took place in Grasbrunn in February 2011 was a 'tailor-made' FPA-5000 technical training.

The Trainer is one with a big T: Ronald Marier; the team was composed of Bosch colleagues from NSO Poland (Ms. Kołodziejczyk, Mr. Kostecki), of representatives from distributor ARPOL and of technical engineers from installer Qumak-Sekom S.A.. Eight players with one goal: the 'National Stadium Warsaw' project, about 7,000 fire detectors, 14 networked FPA-5000 panels. A 55,000-seat stadium that will be staging the UEFA EURO kick-off in 2012. During the first half (training day 1) a session about the 'fundamentals' was

scheduled, but the team demonstrated it wanted to play already in the **Champions League**: we know about the basics, let's go to the hot stuff: RPS advanced, fault avoiding and networking. That is what they wanted to learn and have some more practical experience about.

It was definitely a training camp with many work-out sessions; practical experience is the best teacher: a FPA-5000 network with 12 modified FPA-5000 panels was simulated and participants were able to train themselves in a realistic environment. They discussed, they critically argued, they configured expected scenarios in order to strengthen their knowledge and confidence in the FPA-5000 system.

Mr. Henry Ford, somebody who knew about teamwork once said:

"Coming together is a beginning. Keeping together is progress. Working together is success."

Trainer, representatives and engineers worked together and it was a success. It must be said, team building was definitely easier after a social event; playing a bit together was indeed enough to bowl away shyness and insecurity.

Final whistle: February 18th 12:00 pm. Final score: only winners. Ronald the Trainer congratulates with his team. Now the ball is in the hands of NSO Poland, distributors and technical engineers: but they have definitely the exact know-how and experience to play in the highest League and to make the 'National Stadium Warsaw' Project another Bosch triumph.

Fire

A perfect fit

Modular fire alarm system enables flexible configuration with networked control centers

Fire alarm systems are like good suits; they have to be made to measure. Only if the system really has been tailored to meet the unique requirements of the client or of the location, it is possible to guarantee safety on the one hand and cost-efficient operation on the other. But what happens when the made-to-measure suit has to 'grow' with the customer?

Even the best fire alarm system can only fulfill its role to optimum effect if it is designed entirely in line with the circumstances at each installation location. And it is also important to bear in mind the service life of the installed systems. Fire alarm systems often have a lifecycle that is counted in decades rather than in years. In this period not only the conditions of use at the location change, but also the specific requirements in terms of fire safety and evacuation technology. Together with the changes of use within the life of the system, there are several other good reasons why it is important to look for flexibility and modularity when selecting a fire alarm system.

In order to offer installers and customers an alternative to monolithic systems, Bosch first presented a modular fire alarm system in 2005. This has since been consistently further developed. In the case of the Modular Fire Panel 5000 Series each control panel can accommodate up to 46 functional modules, which can be used to connect LSN elements, signaling devices and display elements or to provide relays or various interfaces. The modular architecture not only enables installers to configure the system to the client's specific needs, but also ensures that it can grow with future requirements without forfeiting the capital investment that has already been made. With one fully equipped control panel it is possible to create systems of medium complexity with up to 4,000 call points and detectors. The networking of several control panels is suitable for large-scale application in extensive industrial areas, shopping centers, airports, etc.

A network of this type can include a maximum of 32 control panels with up to 32,000 call points and detectors.

Simple expansion by means of networking

In the Serdika Center, one of Bulgaria's biggest shopping centers, two control panels were installed and networked together in spite of the fact that there are 'only' 2,400 call points and fire detectors. A third control panel of the Modular Fire Panel 5000 Series within the same network takes care of fire safety in the adjacent office building, where there are a further 1,500 detectors and call points.

This is a good example of decentralized and extensive environments where it may make sense to network several control panels. In this way it is possible to keep short the cable paths from the control panel to peripheral elements, or to separate individual parts of a building logically.

The technical basis of such a network of control centers is formed by the CAN bus (Controller Area Network), which was originally developed by Bosch for the networking of control units in automobiles and was later standardized by ISO. As the CAN bus was developed for critical environmental conditions, it provides a series of data backup mechanisms which also make it ideal for use as a transmission system in safety technology.

A high degree of system stability is guaranteed when the control panels are networked in a ring. In the event of a cable failure the system remains functional and the redundancy conditions according to EN54-2 and EN54-13 are satisfied.

Each control center has two CAN interfaces, so no additional components are required to set up a network. The distance between two control panels in the loop can be up to 1,000 meters. It is also possible to network the control centers via fiber-



Planning fire alarm system



Serdika Center

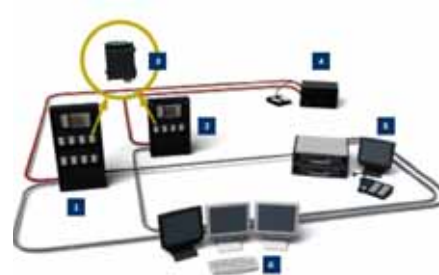

Network configuration

optic cables in conjunction with special CAN/fiber-optic adapters. In this case ranges of up to 15 kilometer can be achieved.

The modular structure of the control panels and the networking of several control panels enable flexible and extendable system configurations. In the Loftus Versfeld Stadium in Pretoria, one of the Soccer World Cup stadiums in South Africa, the local installers managed to satisfy the requirement for the inclusion of other areas in a second section of the building. Three more control panels are now networked with the first Modular Fire Panel 5000 Series, which had already been installed while the stadium was being built.

It would also be possible, for example, to integrate a new building on a factory site, a university campus or in a clinic into the existing fire alarm system.

Flexibility thanks to a large selection of modules

Detectors, call points and peripheral elements are connected via a LSN bus, which is supplied with 300 mA or 1,500 mA by the respective LSN module in the control panel and hence supports cable lengths of 1,600 or 3,000 meters. Each of these modules can connect up to 254 elements in loop, branch or T-tap topologies. For example, with these basic conditions up to 100 base-sounders of the Series 420 from Bosch can be operated.

In addition to the central control unit, the Modular Fire Panel 5000 Series has a large number of sockets into which the functional modules can be plugged in using 'hot-plugging'. This means that cost-intensive wiring errors can be avoided from the outset. It is equally easy to replace a module, which significantly reduces maintenance costs. Furthermore, all the modules are encapsulated and the sensitive electronics are protected even when fitted in rather harsh environment of the building site.

In order to guarantee the greatest possible flexibility, Bosch offers a large number of different modules for the fire alarm control panels, including display modules, open collector outputs, a notification module, relay modules and an interface module for alerting the fire department. A serial interface for the connection of voice evacuation systems is also available.

Voice alarm

When there is a fire, it is not only necessary to call the fire department but also to alert everyone in the building and to guide them as systematically as possible to the clear escape routes. So there are ever more frequent demands for a comprehensible voice announcement appropriate to the situation, instead of the acoustic alarm signals which normal citizens can hardly be expected to interpret correctly. The voice output system is triggered in many cases via contact interfaces, with each contact interface representing a voice announcement for one alarm area. Particularly in the case of larger installations or if different announcements are required for the same alarm area and depending on the situation, this rapidly leads to many parallel inputs and outputs and the corresponding mass of complicated wiring. For that reason an RS-232 data interface has been developed specifically for the Modular Fire Panel 5000 Series and the Plena Public Address and Voice Alarm System. It permits up to 120 inputs of the system to be triggered by means of a monitored data protocol. There is no longer any need for complicated wiring or special interface hardware. Together with the Plena Public Address and Voice Alarm System, the Modular Fire Panel 5000 Series forms an integrated fire alarm and evacuation system.

Controls and displays

The system is operated via the control and display unit that is integrated into the control panel, or via remote control units that are integrated into the CAN network just like a panel. The visually attractive remote control units permit the flexible operation of the entire control panel network, and can be either surface- or flush-mounted. They have the same graphic, multilingual and intuitive user interface as the integrated control and display units. It is helpful and useful to have location information and the control measures initiated in the event of an incident graphically displayed in building plans on computers that are specifically set up for the purpose.

Integration into central management system

The Building Integration System (BIS) centralizes the monitoring and control of all the functions in a building that use network connections, including fire and intruder detection systems, video systems (CCTV) and access control. Emergency exits and elevators



Loftus Versfeld Stadium in Pretoria



Modules of fire alarm control panel



Data interface to Plena Public Address and Voice Alarm System

or escalators can also be controlled by the central system. The Modular Fire Panel 5000 Series has a standardized Ethernet interface (OPC server) for the purpose of integration into the higher-level BIS risk management system. Overall the initiation and coordination of measures is carried out extraordinarily efficiently in this way.

In an environment with a central management system it is also possible for digital sound systems such as the Praesideo Digital Public Address and Emergency Sound System from Bosch to assume warning and evacuation functions. For example, at the new airport in Bratislava three networked FPA-5000 fire alarm control panels have been installed, which can communicate with a Praesideo Digital Public Address and Emergency Sound System system via the BIS. The latter is primarily used for the announcement of travel information, but also for the systematic evacuation of individual sections of the terminal or of the entire terminal, in the event of an alarm.

One system for all applications

As a result of its flexible architecture, the Modular Fire Panel 5000 Series is suitable for all standard fire alarm applications, from small systems through to very large and complex environments. The system complies with the current standards EN54-2 and EN54-4 parts 1 and 2. The Modular Fire Panel 5000 Series also has country-specific certifications and approvals in those cases where they are necessary. The monitoring of transmission paths is carried out according to the current EN54-13 test conditions for short circuits and circuit breaks.

The Fire Panel 1200 Series is particularly effective for applications with only a few detectors and call points. The number of peripheral elements is limited, as is the capacity to expand, but it is attractively priced for small addressable systems. The Fire Panel 1200 Series operates with modules from the Modular Fire Panel 5000 Series; it has an identical user interface and can be configured with

the same programming tool. This means that no relearning is necessary when installing, operating and setting up the system, even for the small application. The installed peripherals can be absorbed when the company grows, which guarantees the security of the investment.

Evolution instead of revolution

The Modular Fire Panel 5000 Series has proven effective with its modular structure, and stable in many different applications and environments. This stable structure has made it possible to expand it by means of consistent evolution and practical orientation to become a fire alarm system that can be effortlessly employed for every application, from a small control panel with a few detectors and call points up to a complex, networked system with loop and hierarchical structures, satisfying all the demands that are placed on a fire alarm system.

Fire

Bosch technology protects Shoppers in Andorra

Networked fire panels installed in Illa Carlemany mall



- ▶ Full coverage of stores, leisure area, and parking garage
- ▶ Central operations increase safety and reduce cost
- ▶ Individual users maintain full control of their alarm systems

 emteandorra



Bosch Security Systems has supplied comprehensive fire detection and alarm technology for the latest shopping mall in Andorra, the Illa Carlemany. Located in the heart of Andorra, the mall houses more than 50 stores, a 2,700 square meter supermarket, five movie theaters, nine restaurants, a children's play area and even a gym. All four floors overlook a central courtyard inside the mall. The complex also includes around 80 apartments and 15 offices as well as three floors for parking with 600 spaces. In total, the entire site covers a surface area of 47,000 square meters.

In order to ensure maximum fire protection in all parts of the complex while at the same time maintaining the autonomy of the different businesses in the mall, the developers decided to install a networked solution based on Bosch's 5000 series of modular fire panels. This allowed them to tailor individual panels to specific needs of the different environments without sacrificing central operations, while still enabling users to maintain exclusive control of their alarm systems.



The main panel was installed in the mall, covering shops, offices, parking garage and public areas. Seven loops with 558 detectors are on watch here. A second panel secures the cinemas by means of 57 detectors, while a third one was installed in the supermarket. All three panels are tightly integrated and operated from a central control room with 24-hour surveillance.

Next to the three fire panels, the overall solution includes an FMR-5000 Signal Repeater and Operation Panel in the garage control room. The state-of-the-art fire detectors are algorithmic and have an Intelligent Signal Processing system to enable them to transmit real alarms in the shortest time possible and to differentiate between real and false alarms. The three-storey parking lot is protected by FAS-420 Aspirating Smoke Detectors, which are able to adapt to the particular operational conditions and protect users effectively.

All of the panels transmit signals to an FMS-2000 Graphic Software system in the central control room, from which security personnel can access all of



the necessary information in real time. To back up the on-premise staff, the end user can also connect remotely via Ethernet in order to check the system's status in real time.

The networked fire alarm system is a vital element in the protection of both associates and visitors of the Illa

Carlemany shopping mall. It automatically activates a discharge system located in the mall's basement, the automatic extinguishers in the projection rooms, ventilation in garages and other safety equipment to maximize safety and minimize damage in case of a fire.



Fire

Bosch products receive CERTALARM quality mark



- ▶ Compliance with current EN 54 standards testified
- ▶ One of the first vendors to receive pan-European mark

Munich – Two families of smoke detectors from Bosch as well as the company's public address and voice evacuation system Praesideo have been awarded the CERTALARM quality mark. They are among the first products to receive this pan-European mark which is endorsed by the European Commission to harmonize certifications in the fire and security industry throughout the European Union.

Bosch products that now carry the CERTALARM mark include the FCP-320 Conventional Optical Smoke Detectors, the FAP-420 Optical Smoke Detectors LSN improved version and Praesideo 3.5. The smoke detectors were testified to be compliant with the EN54-7 standards, while Praesideo was found to comply with EN54-16.

Also, the short circuit isolators within the FAP-420 smoke detectors were successfully tested against EN54-17.

CERTALARM is a scheme which offers third party one-stop testing and certification of fire and security products to provide a single quality mark throughout Europe. It was established as a not-for-profit Association with the express objective of delivering a single voluntary quality mark based on tests by independent third party test laboratories against European standards - the EN54 series for fire products and the EN50131 series for security products. The CERTALARM scheme has been accepted by the European cooperation for Accreditation (EA) as a 'Sector Scheme' under their rules.

Intrusion

Bosch enhances top-selling Blue Line Detectors

Delivers better performance and easier installation



- ▶ Enhancements improve catch performance and false alarm immunity
- ▶ Flexible configuration fits residential and small commercial applications

Bosch Security Systems has launched the next generation of its top-selling Blue Line Motion Detectors. Blue Line Gen 2 provides improved catch performance, enhanced false alarm immunity and easier installation for technicians. Available in standard and pet-friendly models, the new series is suitable for residential, retail and other commercial security applications.

Blue Line Gen 2 Motion Detectors include the passive infrared (PIR), the Quad PIR detectors and the TriTech detectors that combine PIR and microwave technologies for more

advanced analysis. All models use an interchangeable mounting base, enabling easy upgrades to more advanced detection technology in areas prone to false alarms. In addition, pet-friendly models can be set to 'No Pet' to allow customers to use the same product in multiple applications, reducing inventory for security dealers.

For easy installation, the self-locking, two piece enclosure, integrated biaxial bubble level and removable terminal strip in the base reduce mounting time to mere seconds. The commercial grade terminal strip is designed to prevent incorrect wiring and eliminate future service calls. A flexible mounting height allows the detectors to be positioned from 2.3 to 2.7 meters (seven to nine feet) without adjustment, assuring no coverage gaps up to twelve meters (40 feet) away from the detector.

Blue Line Gen 2 Motion Detectors deliver an expanded 12x12 meter

(40x40 feet) wall-to-wall, gap free coverage area. With First Step Processing, the detectors intelligently analyze motion to differentiate human targets from other sources of movement and automatically adjust sensitivity based on signal amplitude, polarity, slope and timing. This advanced technology also ensures the detectors' two sensors agree there is an alarm before the relay activates – delivering an instant response to intruders without false alarms.

A host of additional features provide reliable performance for customers. The sealed optical chamber prevents drafts and insects from affecting the detector, and pet immunity distinguishes between signals caused by humans and animals. Dynamic temperature compensation also adjusts sensitivity to accurately identify intruders regardless of room conditions.

Intrusion

District Savings Bank in Ahrweiler, Germany secures main branch with the Modular Alarm Panel 5000

- ▶ High security standard and open architecture
- ▶ Simple user control thanks to intuitive touch panel

The District Savings Bank Ahrweiler secures its extensively re-designed main branch with the aid of the Modular Alarm Panel 5000 (MAP 5000). The system, which features innovative touch panels as user control units, impressed the savings bank above all on account of its low susceptibility to failure, its high reliability and ease of use.

At the District Savings Bank Ahrweiler, customer service is not only practised by its 36 branches and five self-service points throughout the district, but is now also implemented architecturally. A passageway that is accessible to the public during the day in the main branch creates new connections in the town, but also places exacting requirements on the security technology. For this reason, seismic detectors are used to guard the bank premises during the day, while at night the non-admissible zones including the passageway are monitored by infrared motion detectors.

All the detectors are connected via the LSN local security network with the intrusion alarm system. All the alarm



states of vaults, cash dispensers and the safe deposit box can be read on the simple-to-use touch panel. Since Bosch attached great importance to open interfaces in the development of the MAP 5000, it was also possible to integrate the access control systems. These are also controlled and managed via the touch panel.

The MAP 5000 is a scalable intrusion alarm system for medium to large applications. It permits the rapid and cost-efficient adjustment of the security infrastructure to new conditions such as the integration of a

new adjacent building or a change in the risk situation. It works with up to 32 control units; each of them comes equipped with a colour touch screen, is multi-lingual and can be adapted to suit the needs of the particular customer. As an example, it is possible to set the language depending on the operator and to allow the respective operator access only to the information and functions that are actually relevant for their area of activity. The touch screen guides users through the system with easy-to-understand icons. Access to the menu is protected by means of a PIN code.

Intrusion

Updated Interactive Motion Detector Selection Tool

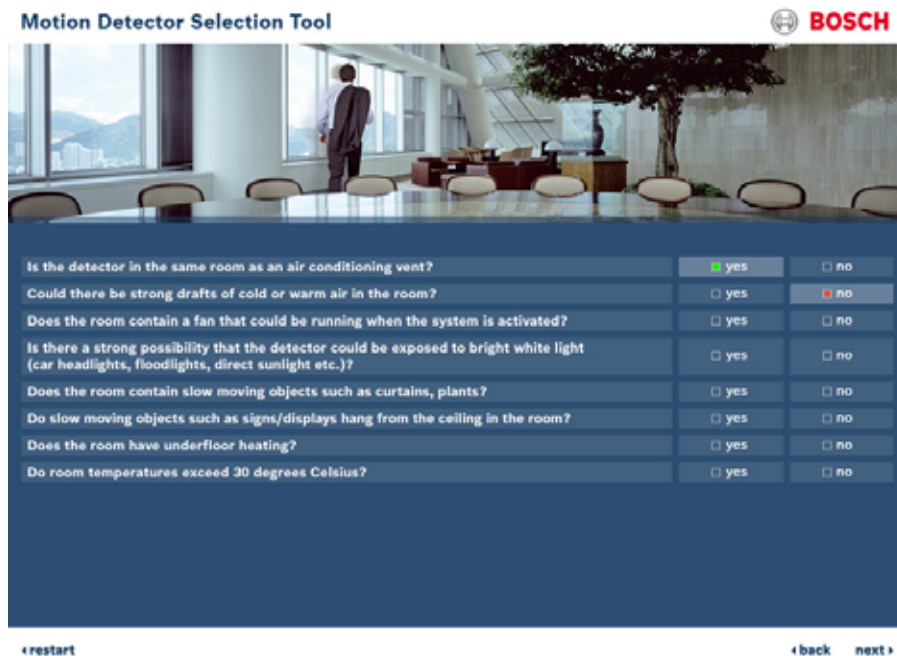

Bosch Security Systems had developed a very effective and simple tool with the aim of helping installers and professional end-users in the selection of motion detectors.

The motion detector selection tool guides the user through a number of questions concerning the level of security required, the difficulty of the environmental conditions, the presence of small animals. In the end, the software will propose to the user the ideal motion detector according to the specific requirements and additional advice from Bosch Security Systems, if required. The importance of choosing the right detector is strengthened by the reduction of false alarms and of costs for the customer.

As new detectors became available, also the software has been updated and it now includes the ISN Motion Detectors and the Professional Series Curtain Motion Detectors.

This is a further proof that Bosch Security Systems continues to show commitment in supporting installers and professional end-users in choosing the motion detectors that suit perfect to their needs.

The updated Motion Detector Selection Tool will be available online on the Bosch Security Systems homepage, can be downloaded and run in any PC.

GIT Security Award 2011

Heiko Baumgartner (right) handed over one of the GIT Security Awards 2011 to Olaf Zeissig from Bosch (left) at the Security exhibition Intersec 2011 in Dubai. The GIT Security Award is nationally and internationally published. The readers of the security magazines GIT SECURITY (international Publication for EMEA region) and GIT SICHERHEIT (DACH region) elect the winners. Bosch won a GIT Security Award 2011 with the Modular Alarm Platform 5000.



Intrusion

Swedish Kindergartens eliminate false alarms with Bosch Professional Series

- ▶ Reliable motion detection in demanding environments
- ▶ Fast return on investment

Munich, Umeå - Umeå Municipality in northern Sweden relies on advanced motion detectors from Bosch to reduce the number of false alarms of intrusion detection systems in three Kindergartens and one school. The city which will be European Capital of Culture in 2014, has drastically reduced false alarms in these facilities since Bosch detectors have been installed more than two years ago.

Intrusion detection by means of motion detectors is particularly difficult in schools and Kindergartens, as these are often characterized by lots of things hanging in windows or from ceilings, such as curtains, drawings or children's handicrafts. Being located in the northern parts of Sweden with winter temperatures frequently going down below -20 or even -30°C, Umeå Kindergartens do often have to run their heaters on full power. This creates a lot of draft which tends to move loose hanging items and thus easily creates false alarms. As a result, the Kindergartens had an average of five false alarms per year each.

When Umeå Municipality's technical department came across Bosch and the Professional Series of motion detectors during a trade show in Stockholm, they immediately decided to do some real life testing. The Professional Series has rigorously been designed with false alarm immunity in mind and is based on a blend of technologies that help to achieve this goal.

Anders Forsberg, a technical engineer who works with security and energy conservation at Umeå Municipality, evaluated both a PIR detector and a TriTech+ detector with Anti-mask technology and was impressed by their behavior: "We made tests with horizontal and vertical movements, with flickering paper, even with direct light from a strong source", Mr. Forsberg reports. "In all situations, the



detectors behaved as we would have liked them to behave, offering one hundred percent detection rate while minimizing the number of false alarms." The detectors also proved sensitive enough to be used as presence detectors for light control in the kindergartens in addition to intrusion detection purposes.

In early 2009, Umeå Municipality installed Professional Series detectors in all three Kindergartens and the school and has since dramatically reduced false alarms to a minimum level. Compared to five false alarms per year each, this saves a lot of money. Anders Forsberg comments: "Return on investment was very fast, and now we continue saving money that can be better used for education purposes."

The Professional Series from Bosch is a comprehensive family of motion detectors that implement a variety of innovative technologies to ensure a cost-effective, failsafe installation. These technologies include TriFocus Optics with three lenses and Sensor Data Fusion (SDF) digital signal processing which correlates signals from up to eight sensors to achieve highest levels of accuracy. The



combination of TriFocus and SDF ensures optimal catch performance and false alarm immunity.

All Professional Series detectors are certified by an accredited lab to the latest EN50131 standards.

Access and Systems

AMC2 - The intelligent and scalable core of the Bosch access control

The AMC2 (Access Modular Controller) is one of the best examples of expertise and reliability in the access control business for Bosch. Scalability is definitely a key feature since up to hundreds of controllers can be connected within one system. This is the case when the AMCs are connected to the ACCESS ENGINE (ACE), which is part of Building Integration System Software (BIS). The BIS is a software used to fully integrate security and safety systems to allow an operator to work from a single user interface.

Besides the Access Engine, AMCs can also be connected to the Access Professional Edition – a software that handles a combination of Video and Access Control. Each AMC controls up to 8 access control readers and in addition other components such as gates, barriers, turnstiles, revolving doors, and sensors can be managed by the controller.

Why is the AMC considered intelligent? The expression is used to highlight its ability to work in a stand-alone mode. Since the access controller stores all necessary information in a battery-buffered memory and a compact flash storage element, it is able to carry out authorization checks on access points, take access decisions, control closing/opening elements and register movement events even when the unit is offline. This can happen in cases when the server may be down or the connection to the controller may be interrupted for events such as maintenance or system upgrade. The AMC2 is the connecting point between the server and the peripheral devices. These peripherals are connected to the server via RS485, RS232 or IP, depending on the cabling choices used with the system. Among all the functions provided by the AMC, it is wise to highlight the following:

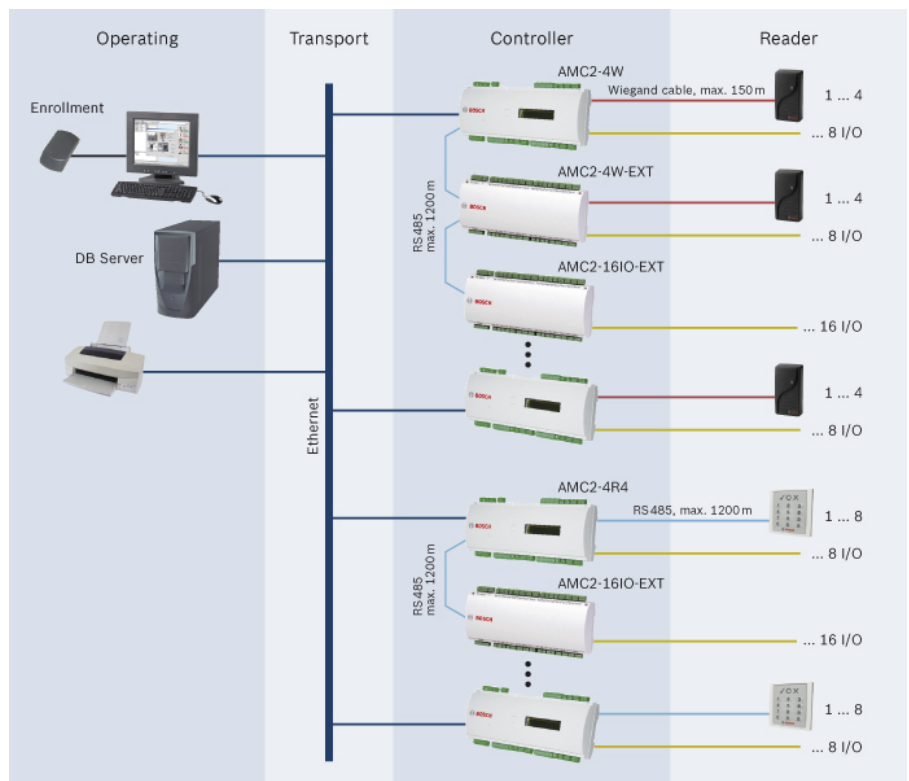

- Ability to **store** downloaded master data, authorizations, access models, display texts, and reader configuration;
- Ability to **react on** access authorization request, host request, and PIN code from the reader;
- Ability to **control and monitor** switching alarms, door status, reader operation status and internal alarm status;
- Ability to **communicate** stored information from devices to the host with delay following network reconnection;
- Ability to **power** readers, electric door strikes and other door devices that require power to operate.

The AMC controller is supported by extensive development experience from Bosch Security Systems. Its reliability is based on the quality of its components, on the fulfillment of several development process steps, and on the rigorous testing that every Bosch product is submitted prior to its launch. As proof to these points, this product has recently received an additional certification. The VdS Certification has now recognized the AMC as a device to arm and disarm an Intrusion Alarm System within the demanding German security industry standards.



Access and Systems

Bosch launches BIS Certified Partner Program



Bosch has launched its new partner program for the Building Integration System (BIS). The Building Integration System is a modular platform for central alarm management and subsystems such as fire and intrusion alarm, video monitoring, access control, and evacuation systems from Bosch and also 3rd party equipment.

Within the framework of this program, BIS Certified Partners can benefit from strong commercial and technical support in all phases of a project – from preparing quotes to compete in a tender to after-sales support. The centerpiece of the program is based on providing the partner with the

necessary knowledge to be successful. In this perspective, Bosch offers modular trainings and exclusive technical information enabling BIS Certified Partners to build up and maintain the levels of expertise in the areas they need for their customer base. Upfront investments are not required, as the training and the certification take place only after the first project is won. Following the training and certification, exclusive technical support is available to certified engineers.

For system integrators, the BIS Certified Partner Program opens up a vast potential for additional growth. First, as an open integration platform, BIS

creates opportunities to sell the entire Bosch portfolio at the initial stage or as an addition to the system over time. Even more interesting, BIS installations typically require ongoing support with system upgrades and a maintenance contract with end-customers which generates recurring revenue.

BIS represents the centerpiece of large safety and security applications in hospitals, shopping malls, airports, universities, production plants, government facilities, stadiums amongst others. More than 1500 sites worldwide successfully implemented the BIS to improve their reaction time and therefore better protect people and assets within their facilities.

Care Solutions

Bosch Care Solutions launches the new social alarm management system LMS 7 Professional

With the recent launch of the LMS 7 Professional Bosch Care Solutions strengthens and streamlines its Social Alarm Management Systems portfolio while offering a high scalable solution.

Starting with a compact version limited to one single user workplace and two telephone lines, the social alarm management system LMS 7 Professional can be extended step by step. Up to 48 telephone lines as well as an unlimited number of operators can be managed by the system at its highest expansion stage.

The CTI option allows the integration of the LMS 7 Professional in an existing telecommunication system (Siemens HighPath 4000).

This gives customers the freedom to decide whether or not to integrate their social alarm monitoring system in their telecommunication system and thus offering enhanced flexibility. Thanks to the available SIP option, the LMS 7 Professional is not only able to receive IP or analogue calls but also calls through an analogue emulated network, making the system a future-proof solution in the area of telecare monitoring.

A further highlight of the product is the Mobile Security application. In cooperation with external location service providers it is possible to receive not only calls from residential carephones but also from various Mobile Security devices outside. Consequently, social alarm customers can, for example, be located in case they have got lost.

Last but not least, the LMS7 is characterised by a secure and well-developed redundancy system. The possibilities of both, on-site redundancy in the office as well as off-site redundancy through database replication ensure highest security standards for social alarm monitoring systems.

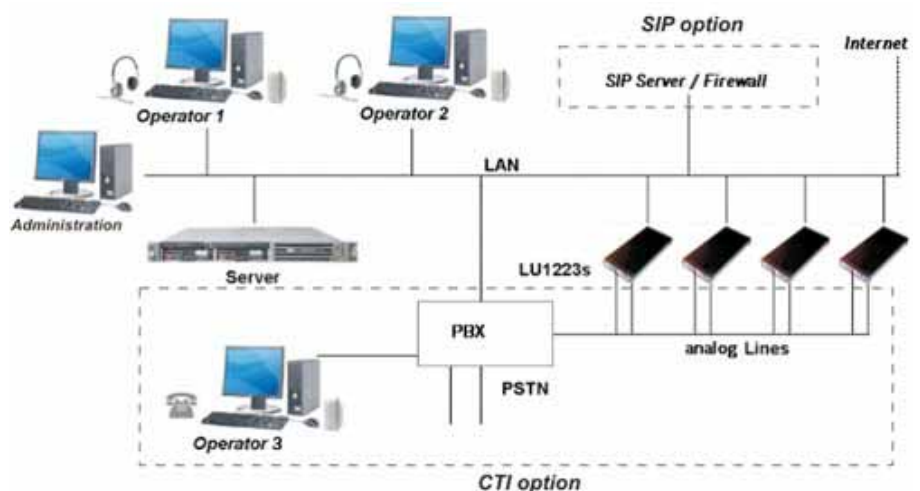

Care Solutions

Introduction of new configuration manager for carephones

Bosch Care Solutions launches with its configuration manager an extensive package that includes the new stand-alone software solution to configure the Carephone 62.

The software tool reads and writes the settings from Harddisk or of a Micro SD card which can then be easily inserted in the Carephone, making the configuration of the device real plug-

and-play. Consequently, time as well as cost advantages for social alarm service providers are guaranteed. Besides the options to configure the Carephone 62 via the integrated keyboard or remotely via the monitoring centre, the configuration manager presents a third programming possibility, offering maximum flexibility and freedom of installation to social alarm service providers.

Additionally, the CD includes not only the TSM software to configure the carephones 10 and 12 but also the event viewer to read and display event history files from the Carephone 62.



Colophon

Editors

Wendy Kleuskens (CCTV)
 Yolanda van der Steen
 (Communications Systems)
 Helmut Seidl
 (Communications Systems)
 Gerhard Kugler (Intrusion)
 Alex Squarize (Access/Systems)
 Josef Angstenberger (Fire)
 Silke Kronimus (Care Solutions)

Coordination

Gerard Mulders RSO EMEA

© Bosch Security Systems 2011